

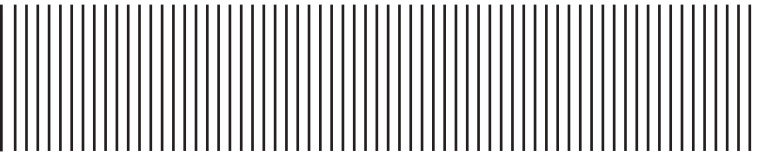

**NOIR
SERIES**



NOIR SERIES | 1000L

Designer sinks with a natural stone look.

1 & 1/2 BOWL & LEFT HAND DRAINER



NOIR SERIES 1000L

The NOIR SERIES of granite sinks offer a contemporary design that is elegant, stylish and very durable. Made from 77% Quartz and 23% acrylic resin, these sinks have the look of natural stone.

Resistant to heat, dents and chips, they will maintain their colour and resist stains for many years.

Sound-resistant quartz means that NOIR SERIES sinks are quieter than stainless steel sinks, as well as being non-porous and resistant to bacteria and odours. Suitable for top mounting, these sinks will complement your modern kitchen.

SPECIFICATIONS

Dimensions

Overall Size: 1000 x 500 x 200mm
Main Bowl Size: 350 x 420 x 200mm
Secondary Bowl Size: 170 x 285 x 155mm
Minimum cabinet size: 650mm
Cut out size: 970 x 470mm
Tap Hole: Drilled

Product Details

Installation: Topmount
Material: 77% Quartz & 23% Acrylic
Colour: Black
Reversible: No

PRODUCT FEATURES

- Impact resistant.
- Heatproof up to 300°C.
- Anti bacterial and extremely hygienic.

Waste & Overflow System

- 2 basket waste, one with overflow kit, clips included.
- 90mm waste hole.

Warranty

5 year peace of mind warranty.

Product Sku Code

Noir 1000L



MM BRANDS
263 Ti Rakau Drive, East Tamaki,
Auckland 2140, New Zealand.

Help & Support
For more information please go
to our website or contact us.

Call: +64 9 274 0111 or 0800 536 252
Email: sales@mmbrands.co.nz
www.sinxbytotara.co.nz

NOIR SERIES | 1000L

DIMENSIONS - LEFT HAND DRAINER

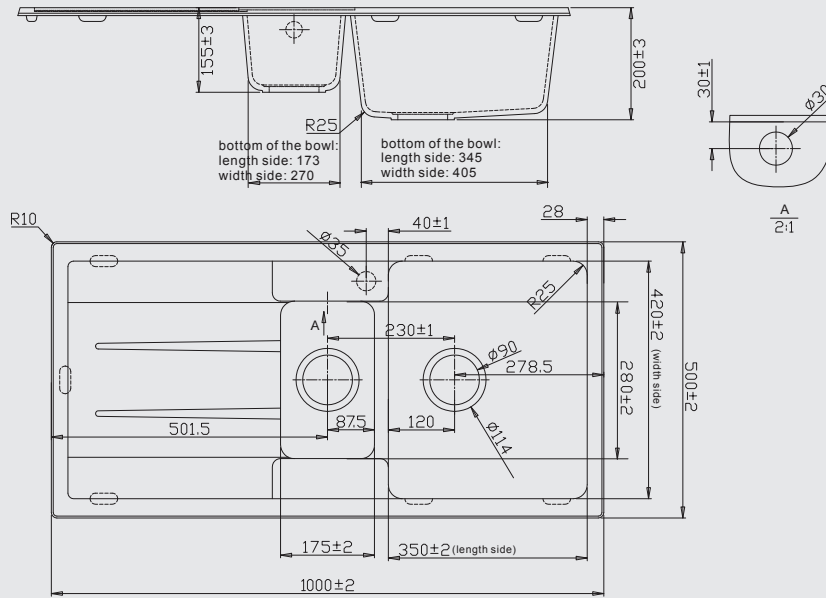

NOIR 1000L

CUT-OUT FOR TOPMOUNT

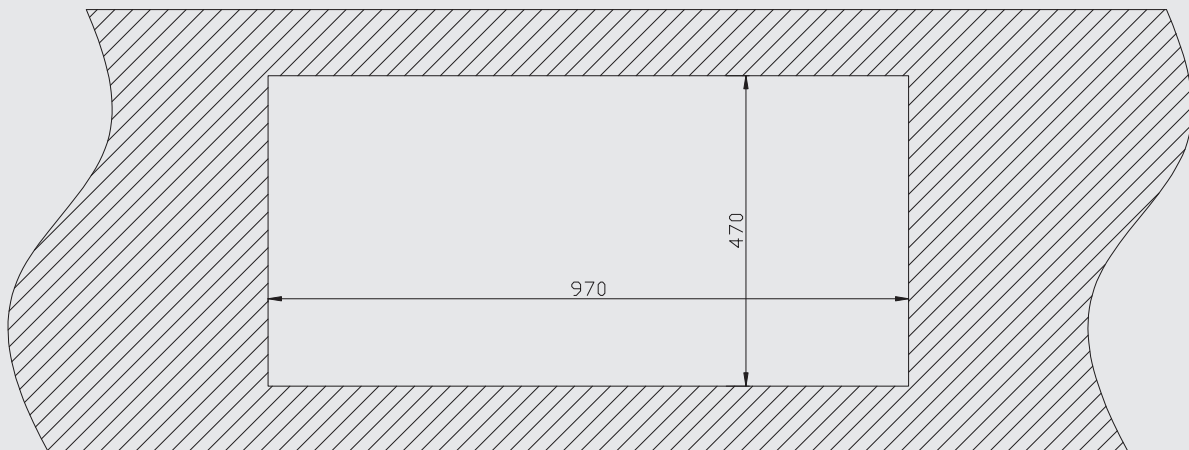

NOIR 1000L

topmount cutout size: 970x470mm